

HYDRAULIC UNIVERSAL PULLERS 50 TON

APHU SERIES



FEATURES

- Double acting cylinder for holding, opening and closing the jaws for safe and secure grip on job.
- The easy jaw operating system prevent puller jaws from sliding and/or springing off the work object always.
- Self-centering design keeps the arms slide inwards or outwards simultaneously.
- Electric Pump advances and retracts the pushing cylinder only to prevent operating errors from happening.
- 50 Ton Cylinder is single-acting, spring return type with a maximum working pressure of 10,000 psi.
- Electric Hydraulic pump is two stage version ; the low pressure stage provides the fast stroking to save time ; the high pressure stage is controlled by remote hand switch.
- Puller can be adjusted 5 degree vertically.
- The cart has two swivel castors which can provide the movement of cart easily.
- Four extensions are included for the needs on extra stroke.

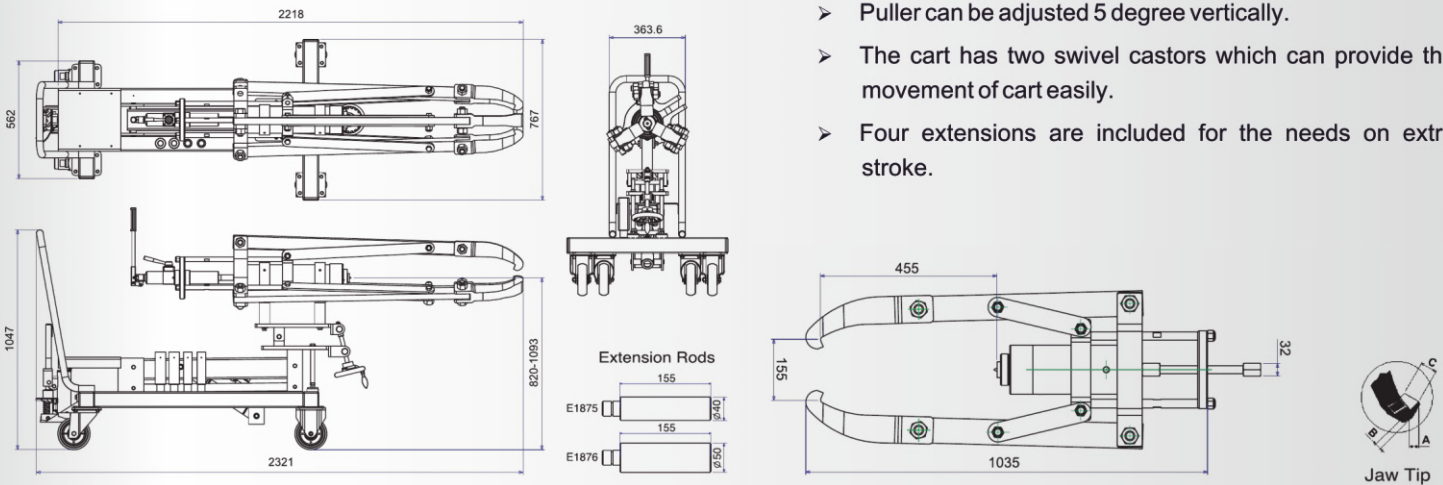

SPECIFICATIONS

Model No.	Reach (Max/mm)	Spread (Min-Max)	Stroke (mm)	Overall Dimensions (mm)	Power Source	Weight (kgs)	Jaw Tip			Extension Rod***	
							A	B	C	E1876	E1875
APHU 50TE*	780	200-1250	330	2545x800x1155	220V / 50Hz	400				2	2
APHU 50T	780	200-1250	330	2545x800x1155	---	369	23	35	60	2	2
APHU 50T**	455	160-860	159	364x1035	---	140				1	1

* This model is equipped with Electric Pump - APE-554.

** The hand pump is not included in this model, recommend model is AHP703.

*** Quantity of extension rod are included.

ELECTRIC PUMP - Specification

Model No.	Acting	Reservoir Capacity (c.c.)	Function	Motor	Oil Del. (c.c./min. @)			
					0 psi	100 psi	5000 psi	10000 psi
APE-554.	Single	8000	Hold/Retract	0.45KW 220V 50/60 Hz Single Phase	4000	2800	330	280