

HYDRAULIC UNIVERSAL PULLERS 100 TON

APHU SERIES

FEATURES

- Double acting hydraulic system for holding, opening & closing jaws for safe & secure grip on work object.
- Self-centering design keeps puller jaws clamp work object evenly and automatically.
- Electrical hydraulic pump advances and retracts the pushing cylinder only to prevent operating errors from happening.
- The easy jaw head adjusting system prevents puller jaws from sliding and spring off the work object being pulled.
- Puller can be converted into 2 or 3-way configurations.
- Puller can be adjusted with 5 degree up/down of puller centerline for precisely positioning.
- The cart swivel castors provide movement of car easily.
- Electrical hydraulic pump is two stage version: the low pressure stage provides the fast stroking to save time; the high pressure stage is controlled by remote switch.
- 100 Ton cylinder is 2-stage, spring return type with a maximum working pressure of 10,000 psi.
- Five extension adapters are standard attachments for the needs on extra stroke.
- Integrated Control System for operating Lift and Push easily and efficiently by Electric Pump only. (Equipment on requesting)

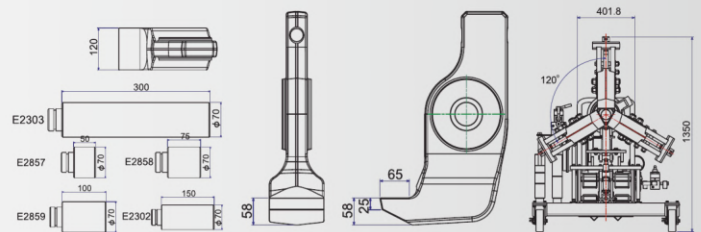
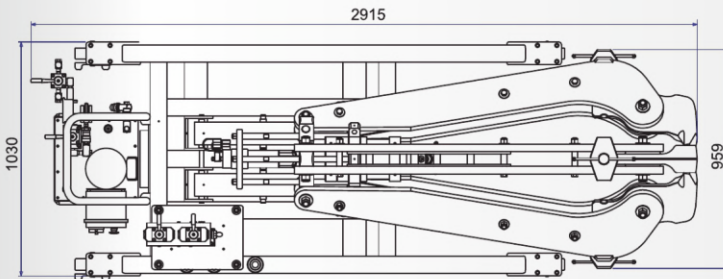
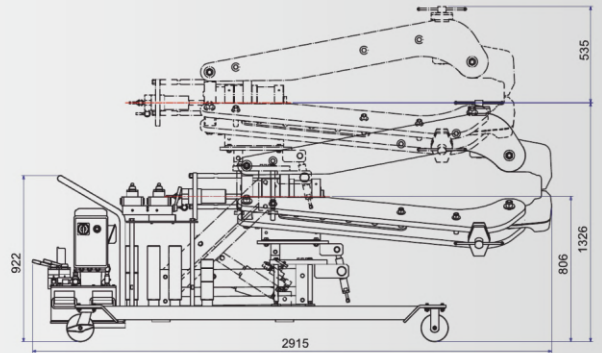

EXTENSIONS & JAW TIP

Part No.	Dia. (mm)	Length (mm)	Qty (pc)	Jaw Tip Dimensions (mm)
AE2857	70	50	1	Tip Depth: 65 Tip Clearance: 25 - 58 Tip Width: 120
AE2858		75	1	
AE2859		100	1	
AE2302		150	2	
AE2303		300	2	

SPECIFICATIONS

Model No.	Reach (Min-Max)	Spread (Min-Max)	Stroke (mm)	Overall Dimensions (mm)	Electric Pump	Weight (kgs)
APHU 100T	952-1220	300-1500	270	2915x1035x1350	APE-554	1083
APHU 100TE*	952-1220	300-1500	270	2915x1035x1350	APE-554	1189

* This model is equipped with the Electric Pumps according to Customer's requirement.