

AERO BOOM[®]

**HIGH FORCE HYDRAULIC
TOOLS & SOLUTIONS**

HYDRAULIC TORQUE WRENCH



OPERATION MANUAL

www.aeroboom.com

info@aeroboom.com

Catalogue

- I. Acceptance notice (unpacking inspection)**
- II. Product description**
- III. Warning**
- IV. Recommendation table of bolt pre-tightening force Comparison**
- V. Operation and Use**
- VI. ASW-XT Hydraulic Torque Wrench Pressure-torque Table**
- VII. ASW-XT exploded diagram and details**
- VIII. After-sales Service**

Operation & Maintenance Manual of Hydraulic Torque Wrench

This operating manual includes operating procedures, warnings and precautions, and troubleshooting of the ASW-XTseries hydraulic torque wrench. Before use, please read this manual carefully, thoroughly understand its content and keep it properly. This manual is only for the end user's reference.

I. Acceptance notice (unpacking inspection)

Check carefully whether there is any damage to the appearance of the product and whether there is any transportation damage. Transportation damage is not covered by the warranty. If it is found to be damaged due to cargo transportation, it should be reported to the freight forwarder in time. The freight forwarder shall pay for all repair and replacement costs caused by transportation damage.

Safety first

Hydraulic torque wrench is a power tool. Read all instructions, warnings and precautions carefully before use, and follow safety measures to avoid personal or equipment damage when operating the equipment! We are not responsible for damage caused by unsafe operation and wrong operation.

II. Product description

The ASW-03 hydraulic torque wrench is made of aluminum-titanium alloy and ultra-high-strength alloy materials. It is manually controlled and has a double-acting hydraulic design, which can tighten and loosen bolt connections. It is widely used for the dis-assembly of high torque bolts, the torque is accurately adjustable, and the error does not exceed $\pm 3\%$.

ASW-XT Hydraulic Torque Wrench:

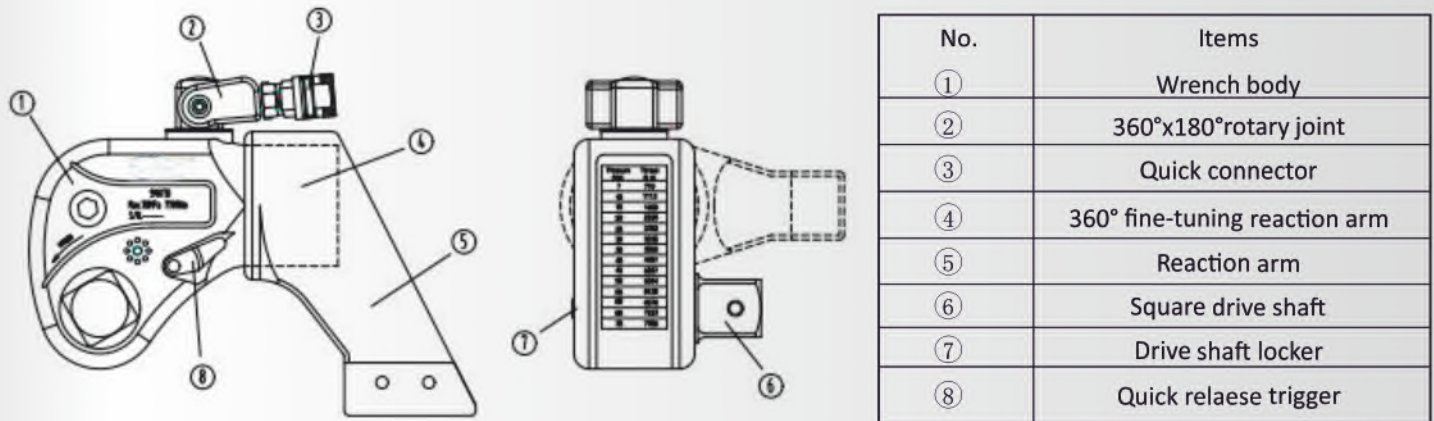
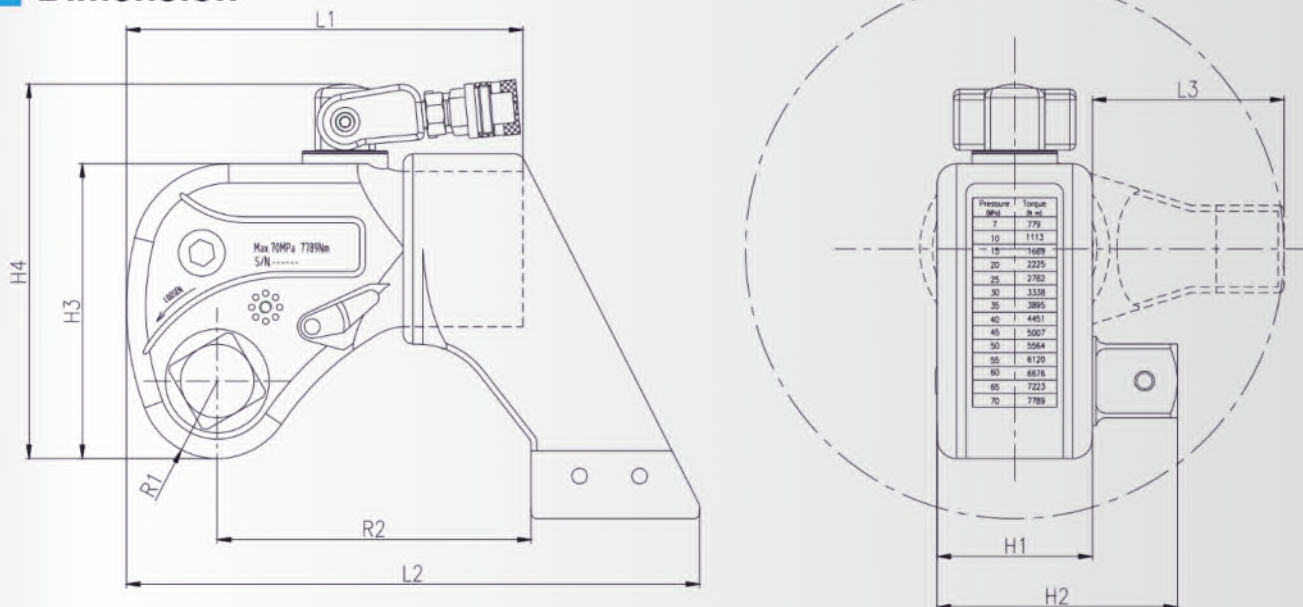

Figure (1)

ASW-03 Technical Parameters:

Dimension



III. Warning



Warning: To avoid personal injury and possible equipment damage, ensure that each hydraulic component can withstand a working pressure of 700bar.



Warning: Do not exceed the rated load of the equipment

Minimize the risk of overloading; use a pressure gauge in the system to display the operating load. The pressure gauge is a window of what happens in the system.

Do not exceed the maximum allowable torque when using a hydraulic wrench.



Warning: Try to replace worn-out parts with original Aeroboom parts



Note: Avoid damage to hydraulic tubing

Avoid serious bending and entanglement of hydraulic tubing during use. The use of bent or wound tubing will produce excessive back pressure. Severe bending and entanglement will damage the inside of the tubing and cause it to be scrapped prematurely.

Do not drop or press heavy objects on the oil pipe. Severe impact can cause damage to the metal wires inside the tubing, and the damaged tubing may rupture when pressurized.

Do not use hydraulic tubing to pull or lift other hydraulic components (such as pumps, hydraulic wrenches, valves, etc.).



Warning: In order to avoid damage to the equipment and personal injury, do not remove the protective plate on the wrench, do not modify the wrench and accessories, and do not change the safety valve on the rotary joint.



Note: Incorrect connection will cause malfunction and danger. Keep the quick connector clean before connecting, and screw on the dust cap after use



Note: Do not use worn-out sockets and plugs. Do not use metric sockets to twist inch nuts and bolts, and vice versa.



Warning: Use Aeroboom original high-performance sockets.



Warning: Fasten the drive head of the socket with a pin to prevent the socket from falling off.

IV. Recommendation table of bolt pre-tightening force

Strength grade		4.8		6.8		8.8		10.9		12.9	
Minimum breaking strength		400MPa		600MPa		800MPa		1000MPa		1200MPa	
Material		General structural steel		Steel for mechanical structure		Chrome Molybdenum Alloy Steel		Nickel-chromium-molybdenum alloy steel		Nickel-chromium-molybdenum alloy steel	
Bolt	Nut opposite side	Torque value		Torque value		Torque value		Torque value		Torque value	
		KGM	NM	KGM	NM	KGM	NM	KGM	NM	KGM	NM
16	24	9	87	13	131	18	174	25	245	30	294
18	27	13	128	20	192	26	256	37	360	44	432
20	30	17	170	26	256	35	341	49	479	59	575
22	34	24	232	36	348	47	465	69	653	80	784
24	36	30	294	45	442	60	589	84	828	101	994
27	41	44	432	66	647	88	863	124	1214	149	1457
30	46	60	585	89	877	119	1171	168	1646	201	1975
33	50	81	796	122	1195	162	1593	228	2240	274	2688
36	55	104	1023	157	1535	209	2046	294	2878	352	3453
39	60	135	1324	203	1986	270	2649	380	3725	456	4469
42	65	167	1638	251	2457	334	3277	470	4608	564	5529
45	70	209	2045	313	3068	417	4090	587	5752	704	6903
48	75	251	2461	376	3691	502	4921	706	6921	847	8305
52	80	325	3181	487	4771	649	6362	913	8946	1095	10736
56	85	404	3956	605	5934	807	7912	1135	11127	1362	13352
60	90	504	4932	755	7398	1006	9864	1415	13871	1698	16645
64	95	608	5960	912	8940	1216	11920	1710	16762	2052	20115
68	100	738	7230	1107	10845	1475	14460	2075	20335	2450	24401
72	105	885	8669	1327	13003	1769	17337	2488	24381	2985	29257
76	110	1050	10287	1574	15430	2099	20573	2952	28931		34717
80	115	1234	12094	1851	18141	2468	24188	3471	34014		40815
85	120	1493	14636	2240	21953	2987	29271		41163		49395
90	130	1787	17510	2680	26266	3573	35021		49248		59098
100	145	2484	24341	3726	36512		48683		68460		82152
110	155	3342	32751		49126		65501		92111		110533
120	175	4378	42902		64354		85805		120663		144795
125	180		48683		73024		97366		136920		164304

Note: The values in the table are measured when the bolt reaches 60% of the yield limit.

The recommended tightening torque is: the value in the table × (70-80)%

For example: M52, 8.8 grade bolt, the tightening torque is 6362 × (70-80)% = 4453-5090 N.m

The loosening torque is 1.5-2 times the tightening torque

For example: in the above example, the tightening torque is 4453 N.m, then the loosening torque is 4453 × 2 = 8906 N.m

V. Operation and Use

Connect:

The wrench and the hydraulic pump are connected by the compound oil pipe woven with steel wire with working pressure of 700bar.

The bottom end of each oil pipe has a female connector and a male connector to ensure the correct connection between the pump and the wrench.

Do not change any bolts on the rotary joint at will. This is set by the manufacturer for safety. Only those who have received professional training can adjust

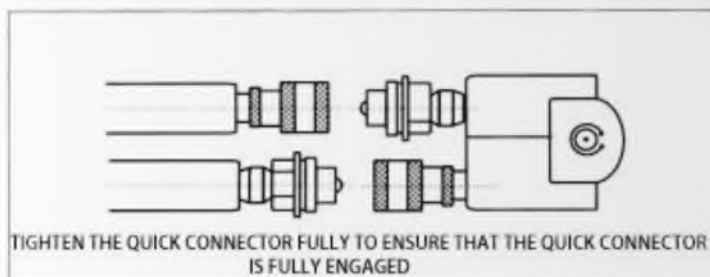

F (3)

When the quick connectors are interconnected, the distance between the gaps after engagement must be less than 1mm (Figure 4). Only in this way can the one-way valve in the connector be opened to make the oil path unblocked. Otherwise, after the connection, the steel ball in the joint does not match up, and the one-way valve in the joint cannot be opened and the oil circuit is blocked. Then the joint will be full of pressure, and the wrench will not work and the oil will be discharged from the automatic drain port on the wrench rotating body, etc.

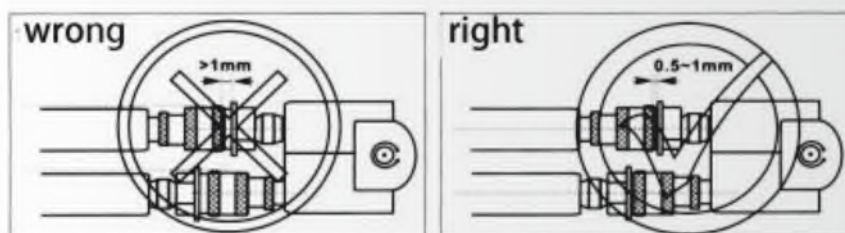

F (4)

At this time, you need to disassemble all the hose joints, check all the steel balls in the quick joints, including the wrench joints, and check whether the steel balls can be pressed with your hands and are flexible. If you can't press it, you need to find a hammer to hit the steel ball in the joint (Figure 5) to release the pressure in the joint (please note that hydraulic oil will spray out when you hit the steel ball. Although it is not dangerous, it will stain your Clothes!) until the steel ball in the joint can be pressed by hand. Then reconnect again.

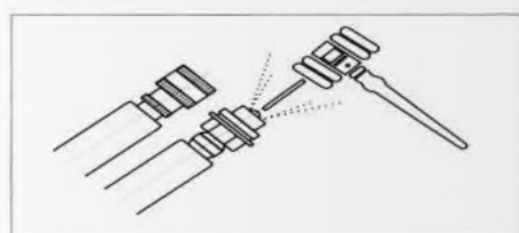

F (5)

Changing over of the drive

Press the round button in the middle of the locker (Figure 6), and gently pull the drive shaft to release the engagement between the drive shaft and the locker, and then the drive shaft can be pulled out.

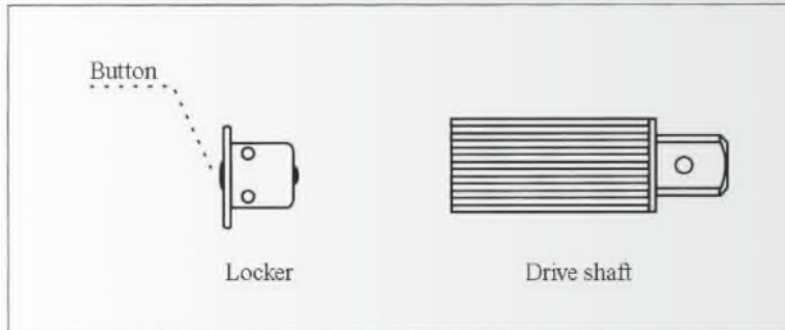
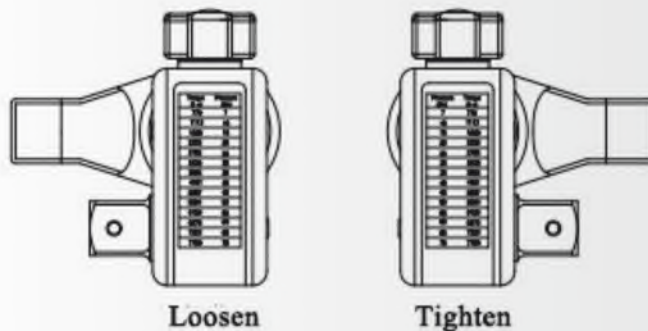

Figure (6)

Put the drive shaft into the wrench, determine the direction (Figure 7), make it fully mesh with the spline sleeve, then rotate the drive shaft to mesh with the spline sleeve and the ratchet groove, and drive the drive shaft to rotate through the ratchet.



Left-Loosen

Right-Tighten

Figure (7)

Preparation

Determine whether to loosen or tighten the nut.

Press down the drive shaft locker; take out the square drive shaft; perform left-right reversal according to the diagram, and install the drive shaft locker; connect the arm clamp on the reaction arm, and install the reaction arm according to the appropriate position. When removing the lock, the direction of the square shaft is shown in the figure (7).

Connect pump station

Connect the high-pressure outlet (H or A) of the pump with the high-pressure outlet (H or A) of the hydraulic wrench, and connect the low-pressure outlet (B or R) of the pump with the low-pressure outlet (B or R) of the hydraulic wrench with high-pressure hose respectively. When connecting, the quick connector on the oil pipe should be inserted to the end, and then tighten the fixing nut by hand.

Check carefully whether the oil pipe joints are connected reliably and whether there is oil in the pump.

Plug the power plug of the pump into the power source.

Warning Operation without oil is strictly prohibited!

Commissioning

Place the wrench on the open floor.

Turn on the power switch of the pump, start the pump, and check whether the pump is running normally.

Press any button on the wire control switch, and the square shaft starts to rotate at this time. When you hear a "click", the reset trigger jumps down, the wrench stops rotating when it is in place, and the pressure gauge rises from "0" to the set pressure. Release the button and the wrench will return automatically;

When a "click" is heard again, the wrench will automatically return to its position, and the pressure gauge will rise rapidly from "0" to 7.5Mpa. Press the button again, at this time the wrench turns, and a new cycle begins. Repeat several times, let the wrench run idly several times, and observe the direction of the wrench to determine whether to put the wrench on the socket.

Note: When the wrench is not in use, turn off the power of the oil pump immediately!

Operating

Adjust pressure

Press the line control switch button with one hand. When you hear a "click" of the wrench, the reset trigger jumps down, the wrench stops rotating when the wrench is in place, and the pressure gauge rises rapidly from "0", and adjusts the oil pump pressure regulating valve with the other hand to adjust the pressure gauge pointer to the required pressure.

Loosening

Adjust the pumping station pressure to the highest, confirm the rotating direction of the wrench. After confirming the direction is to loosen, put the wrench on the nut, find the reaction fulcrum, hold it firmly, and repeat the third action in the Commissioning until the nut is removed.

Tightening

1. Torque setting

First, the torque can be set according to the design requirements; if there is no design torque, it is recommended to set the torque according to the data in the bolt pre-tightening force recommendation table.

The specific method is: set torque = (value in the table) × (70%-80%)

For example: 8.8 grade, M48 is a bolt, the recommended pre-tightening force in the table is 4921N.m, then the set torque is: $4921 \times 75\% = 3691\text{N.m}$.

2. Pump station pressure setting

Set the pumping station pressure according to the required torque value and the type of wrench used.

For example, the bolt setting torque of the above 8.8 level and M48 is 3691N.m, and select the ASW-3XT wrench. From the table, you can check that when the ASW-3XT corresponds to the 3691N.m torque, the pump station pressure is 59Mpa, so the pump station pressure should be set to 59Mpa.

3. Make sure that the direction of the wrench is in the tightening direction, and place the wrench on the nut and repeat the actions of the third item in the Commissioning until the nut does not move.

When the wrench is stuck tightly during use:

In operation, after the bolts are tightened, if the wrench cannot be removed, do not hit it with a hammer; instead, press and hold the wire control switch (button), then press and hold the quick release lever (Figure 12) and at this time release the button, the wrench will be automatically released. Remove the wrench then.

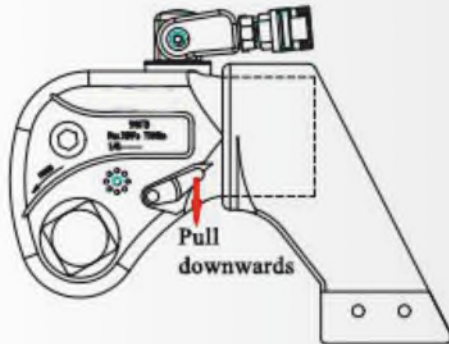

Figure (8)

VI. ASW Hydraulic Torque Wrench Pressure-torque Comparison Table

Model	ASW-1XT	ASW-3XT	ASW-5XT	ASW-8XT	ASW-10XT	ASW-15XT	ASW-20XT	ASW-25XT	ASW-35XT	ASW-45XT	ASW-50XT
Pressure MPa	Torque Nm	Torque Nm	Torque Nm	Torque Nm	Torque Nm	Torque Nm	Torque Nm	Torque Nm	Torque Nm	Torque Nm	Torque Nm
7	185	436	779	1072	1553	2050	2617	3493	4963	6009	7032
8	212	499	890	1225	1775	2343	2991	3992	5672	6867	8036
9	238	561	1001	1378	1996	2636	3365	4491	6381	7726	9041
10	265	623	1113	1531	2218	2929	3739	4990	7090	8584	10045
11	291	686	1224	1684	2440	3222	4113	5489	7798	9442	11050
12	318	748	1335	1837	2662	3514	4486	5988	8507	10301	12054
13	344	810	1447	1990	2884	3807	4860	6487	9216	11159	13059
14	370	873	1558	2143	3106	4100	5234	6986	9925	12018	14063
15	397	935	1669	2296	3327	4393	5608	7484	10634	12876	15068
16	423	998	1780	2449	3549	4686	5982	7983	11343	13734	16072
17	450	1060	1892	2602	3771	4979	6356	8482	12052	14593	17077
18	476	1122	2003	2755	3993	5272	6730	8981	12761	15451	18081
19	503	1185	2114	2908	4215	5565	7104	9480	13470	16310	19086
20	529	1247	2225	3062	4436	5857	7477	9979	14179	17168	20090
21	556	1309	2337	3215	4658	6150	7851	10478	14888	18026	21095
22	582	1372	2448	3368	4880	6443	8225	10977	15597	18885	22099
23	609	1434	2559	3521	5102	6736	8599	11476	16306	19743	23104
24	635	1496	2671	3674	5324	7029	8973	11975	17015	20602	24108
25	662	1559	2782	3827	5546	7322	9347	12474	17724	21460	25113
26	688	1621	2893	3980	5767	7615	9721	12973	18433	22318	26117
27	715	1683	3004	4133	5989	7908	10095	13472	19142	23177	27122
28	741	1746	3116	4286	6211	8200	10468	13971	19851	24035	28126
29	767	1808	3227	4439	6433	8493	10842	14470	20560	24894	29131
30	794	1870	3338	4592	6655	8786	11216	14969	21269	25752	30135
31	820	1933	3449	4745	6876	9079	11590	15468	21978	26610	31140
32	847	1995	3561	4898	7098	9372	11964	15967	22687	27469	32144
33	873	2057	3672	5051	7320	9665	12338	16466	23395	28327	33149
34	900	2120	3783	5205	7542	9958	12712	16965	24104	29186	34153
35	926	2182	3895	5358	7764	10251	13086	17464	24813	30044	35158
36	953	2244	4006	5511	7986	10543	13459	17963	25522	30902	36162
37	979	2307	4117	5664	8207	10836	13833	18462	26231	31761	37167
38	1006	2369	4228	5817	8429	11129	14207	18961	26940	32619	38171
39	1032	2431	4340	5970	8651	11422	14581	19460	27649	33478	39176
40	1059	2494	4451	6123	8873	11715	14955	19959	28358	34336	40180
41	1085	2556	4562	6276	9095	12008	15329	20458	29067	35194	41185
42	1111	2618	4673	6429	9317	12301	15703	20957	29776	36053	42189
43	1138	2681	4785	6582	9538	12594	16077	21456	30485	36911	43194
44	1164	2743	4896	6735	9760	12886	16450	21954	31194	37769	44198
45	1191	2806	5007	6888	9982	13179	16824	22453	31903	38628	45203
46	1217	2868	5119	7041	10204	13472	17198	22952	32612	39486	46207
47	1244	2930	5230	7195	10426	13765	17572	23451	33321	40345	47212
48	1270	2993	5341	7348	10647	14058	17946	23950	34030	41203	48216
49	1297	3055	5452	7501	10869	14351	18320	24449	34739	42061	49221
50	1323	3117	5564	7654	11091	14644	18694	24948	35448	42920	50225
51	1350	3180	5675	7807	11313	14936	19068	25447	36157	43778	51230
52	1376	3242	5786	7960	11535	15229	19441	25946	36866	44637	52234
53	1403	3304	5898	8113	11757	15522	19815	26445	37575	45495	53239
54	1429	3367	6009	8266	11978	15815	20189	26944	38283	46353	54243
55	1456	3429	6120	8419	12200	16108	20563	27443	38992	47212	55248
56	1482	3491	6231	8572	12422	16401	20937	27942	39701	48070	56252
57	1508	3554	6343	8725	12644	16694	21311	28441	40410	48929	57257
58	1535	3616	6454	8878	12866	16987	21685	28940	41119	49787	58261
59	1561	3678	6565	9031	13088	17279	22059	29439	41828	50645	59266
60	1588	3741	6676	9185	13309	17572	22432	29938	42537	51504	60270
61	1614	3803	6788	9338	13531	17865	22806	30437	43246	52362	61275
62	1641	3865	6899	9491	13753	18158	23180	30936	43955	53221	62279
63	1667	3928	7010	9644	13975	18451	23554	31435	44664	54079	63284
64	1694	3990	7122	9797	14197	18744	23928	31934	45373	54937	64288
65	1720	4052	7233	9950	14418	19037	24302	32433	46082	55796	65293
66	1747	4115	7344	10103	14640	19330	24676	32932	46791	56654	66297
67	1773	4177	7455	10256	14862	19622	25050	33431	47500	57513	67302
68	1800	4239	7567	10409	15084	19915	25423	33930	48209	58371	68306
69	1826	4302	7678	10562	15306	20208	25797	34429	48918	59229	69311
70	1852	4364	7789	10715	15528	20501	26171	34928	49627	60088	70315

ASW-XT - Details

No.	Item	Qty.	Wrench Model									
			ASW-1XT	ASW-3XT	ASW-XT5	ASW-8XT	ASW-10XT	ASW-15XT	ASW-20XT	ASW-25XT	ASW-35XT	ASW-50XT
1	Case	1	1M-1	3M-1	5M-1	8M-1	10M-1	15M-1	20M-1	25M-1	35M-1	50M-1
3	Reaction Arm	1	1M-3	3M-3	5M-3	8M-3	10M-3	15M-3	20M-3	25M-3	35M-3	50M-3
4	Baffle	2	1M-4	3M-4	5M-4	8M-4	10M-4	15M-4	20M-4	25M-4	35M-4	50M-4
5	Drive shaft	1	1M-5	3M-5	5M-5	8M-5	10M-5	15M-5	20M-5	25M-5	35M-5	50M-5
6	Ratchet	1	1M-6	3M-6	5M-6	8M-6	10M-6	15M-6	20M-6	25M-6	35M-6	50M-6
7	Bushing	2	1M-7	3M-7	5M-7	8M-7	10M-7	15M-7	20M-7	25M-7	35M-7	50M-7
8	Copper sleeve	2	1M-8	3M-8	5M-8	8M-8	10M-8	15M-8	20M-8	25M-8	35M-8	50M-8
10	Non-return claw	1	1M-10	3M-10	5M-10	8M-10	10M-10	15M-10	20M-10	25M-10	35M-10	50M-10
11	Magnesium fixing cap	1	1M-11	3M-11	5M-11	8M-11	10M-11	15M-11	20M-11	25M-11	35M-11	50M-11
13	Elastic pin	1	1M-13	3M-13	5M-13	8M-13	10M-13	15M-13	20M-13	25M-13	35M-13	50M-13
14A	Trigger-right	1	1M-14A	3M-14A	5M-14A	8M-14A	10M-14A	15M-14A	20M-14A	25M-14A	35M-14A	50M-14A
14B	Trigger-left	1	1M-14B	3M-14B	5M-14B	8M-14B	10M-14B	15M-14B	20M-14B	25M-14B	35M-14B	50M-14B
18	Check spring	1	1M-18	3M-18	5M-18	8M-18	10M-18	15M-18	20M-18	25M-18	35M-18	50M-18
19	Pin shaft	1	1M-19	3M-19	5M-19	8M-19	10M-19	15M-19	20M-19	25M-19	35M-19	50M-19
26A	Bottom cover	1	1M-26A	3M-26A	5M-26A	8M-26A	10M-26A	15M-26A	20M-26A	25M-26A	35M-26A	50M-26A
26B	Steel sleeve	1	1M-26B	3M-26B	5M-26B	8M-26B	10M-26B	15M-26B	20M-26B	25M-26B	35M-26B	50M-26B
27	Pawl spring	2	1M-27	3M-27	5M-27	8M-27	10M-27	15M-27	20M-27	25M-27	35M-27	50M-27
30	Snap ring	2	1M-30	3M-30	5M-30	8M-30	10M-30	15M-30	20M-30	25M-30	35M-30	50M-30
31	Dustproof board	1	1M-31	3M-31	5M-31	8M-31	10M-31	15M-31	20M-31	25M-31	35M-31	50M-31
32	Flat head screws	4	1M-32	3M-32	5M-32	8M-32	10M-32	15M-32	20M-32	25M-32	35M-32	50M-32
34	Claw fixing plate	1	1M-34	3M-34	5M-34	8M-34	10M-34	15M-34	20M-34	25M-34	35M-34	50M-34
37	Countersunk screw	2	1M-37	3M-37	5M-37	8M-37	10M-37	15M-37	20M-37	25M-37	35M-37	50M-37
38	Claw spring	1	1M-38	3M-38	5M-38	8M-38	10M-38	15M-38	20M-38	25M-38	35M-38	50M-38
39	Claw	1	1M-39	3M-39	5M-39	8M-39	10M-39	15M-39	20M-39	25M-39	35M-39	50M-39
40	Elastic pin	2	1M-40	3M-40	5M-40	8M-40	10M-40	15M-40	20M-40	25M-40	35M-40	50M-40
42	Elastic pin	1	1M-42	3M-42	5M-42	8M-42	10M-42	15M-42	20M-42	25M-42	35M-42	50M-42
43	Protective pad	1	1M-43	3M-43	5M-43	8M-43	10M-43	15M-43	20M-43	25M-43	35M-43	50M-43
44	Elastic pin	2	1M-44	3M-44	5M-44	8M-44	10M-44	15M-44	20M-44	25M-44	35M-44	50M-44
45	Claw pin	1	1M-45	3M-45	5M-45	8M-45	10M-45	15M-45	20M-45	25M-45	35M-45	50M-45
48	Pin hole cap	2	1M-48	3M-48	5M-48	8M-48	10M-48	15M-48	20M-48	25M-48	35M-48	50M-48
61	Piston group	1	1M-61	3M-61	5M-61	8M-61	10M-61	15M-61	20M-61	25M-61	35M-61	50M-61
63	Pawl	1	1M-63	3M-63	5M-63	8M-63	10M-63	15M-63	20M-63	25M-63	35M-63	50M-63
001	Connector group	1	1M-001	3M-001	5M-001	8M-001	10M-001	15M-001	20M-001	25M-001	35M-001	50M-001
001A	Push-in connector	1	1M-001A	3M-001A	5M-001A	8M-001A	10M-001A	15M-001A	20M-001A	25M-001A	35M-001A	50M-001A
001B	push-in connector	1	1M-001B	3M-001B	5M-001B	8M-001B	10M-001B	15M-001B	20M-001B	25M-001B	35M-001B	50M-001B

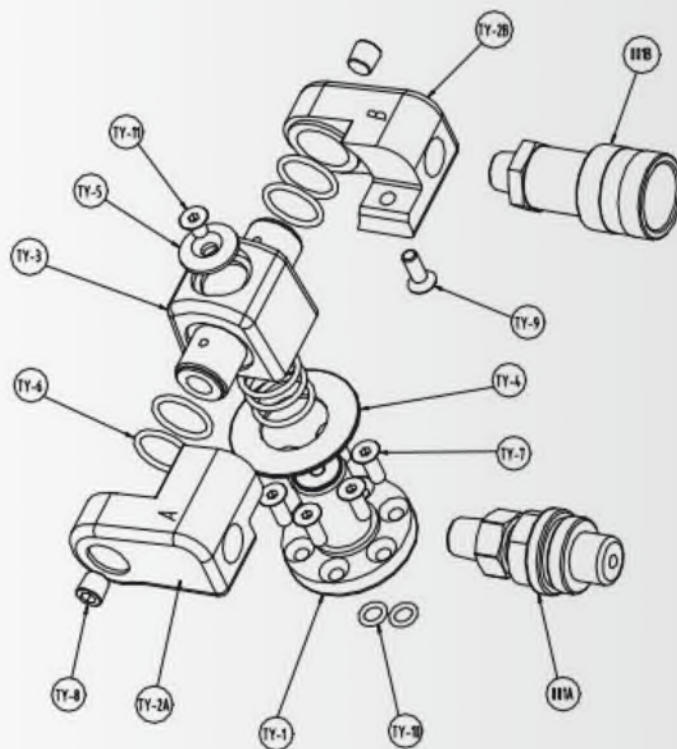

No.	Item	Qty.	Model
TY-1	Connector base	1	-
TY-2A	Connector-A	1	-
TY-2B	Connector-B	1	-
TY-3	Connector body	1	-
TY-4	Cover plate	1	-
TY-5	Cap	1	-
TY-6	O-ring	7	d18*2
TY-7	Screw	6	M5*14
TY-8	Plugging	2	NPT1/8
TY-9	Screw	1	M5*16
TY-10	O-ring	2	d4.15*1.9
TY-11	Screw	1	M5*8
00 1A	Quick push-in connector (male)	1	C701E-M
00 1B	Quick push-in connector (female)	1	C701E-F

VIII. After-sales service

Please read this manual carefully before requesting Aeroboom after-sales service department to repair the wrench. Please do not repair the wrench by yourself without the approval of the authoritative department of our company.



WORLDWIDE HYDRAULIC SOLUTIONS

AEROBOOM CORPORATION

INDIA

Laxmi Industrial Estate, Suite No: 617, 6th Floor, Laxmi Plaza,
New Link Road, Andheri (W) Mumbai - 400053, Maharashtra, India.
Ph: +91-22-4010 4288

GERMANY

Hans Geiger-Str, 221465 Reinbek Germany.

UNITED KINGDOM

124 City Road, London, EC1V 2NX, United Kingdom.

YOUR NEAREST DISTRIBUTOR



Email: info@aeroboom.com

Web: www.aeroboom.com

LIFETIME WARRANTY

Aeroboom warrants all of its products to be free from defects in material and workmanship for the life of the product. This warranty applies to original purchaser and is not transferable. Damaged components, including broken welds, dented or crushed cylinder walls, bent pistons, or couplers are the result of misuse, and are not covered under this warranty. Items such as seals, o-ring and spring wearing out shall not constitute a defect and shall not be considered for warranty credit. We believe that the Aeroboom products you purchase will meet or exceed your performance requirements. However, in the unlikely event that an Aeroboom product fails due to material or workmanship defect please contact Aeroboom, to have it resolved.



Aeroboom does reserve the right to make changes to the specifications of any product or discontinue any product, contained within this catalogue without prior notice.

