

**AERO BOOM<sup>®</sup>**

**HIGH FORCE HYDRAULIC  
TOOLS & SOLUTIONS**

# **SINGLE ACTING LOW HEIGHT CYLINDER**

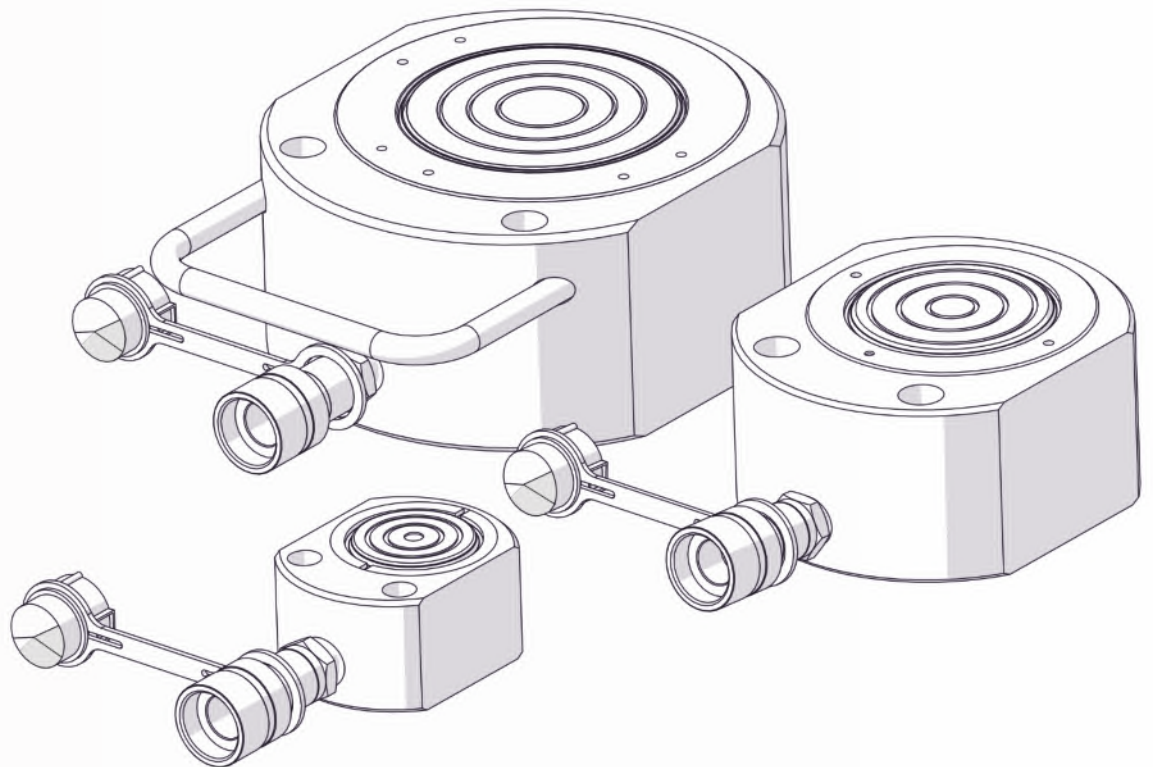

## **OPERATION MANUAL**

## Table of Contents

1.0 Inspection upon Receipt .....	3
2.0 Safety Precautions.....	3
3.0 Declaration of Incorporation / Conformity .....	6
4.0 Component Identification .....	6
5.0 Installation / Setup .....	8
6.0 Operation .....	10
7.0 Maintenance and Storage.....	10
8.0 Specifications.....	11
9.0 System Components / Accessories .....	12
10.0 Troubleshooting .....	13
11.0 Contact Details .....	Error! Bookmark not defined.



## 1.0 Inspection upon Receipt

Upon receipt of the product, visually inspect the item for any evidence of shipping damage. Please note: the warranty does not cover shipping damage. Notify the courier immediately if shipping damage is found and refrain from putting the product into service. The carrier is responsible for repair and replacement costs resulting from damage that occurred in transit.

## 2.0 Safety Precautions

### 2.1 Introduction



Read and follow all the instructions and safety warnings carefully before handling, installation or use of any hydraulic equipment. Failure to do so could lead to equipment damage, equipment failure, personal injury or even death. Aeroboom will not be held responsible for any damage to the equipment, injury or death resulting from the unsafe use of, lack of maintenance to, or incorrect operation of the product. If in doubt on the correct use of any Aeroboom equipment, contact your nearest Aeroboom office or distributor. Only qualified personnel be allowed to operate hydraulic equipment. If an operator has not been trained on high-pressure hydraulic equipment and its safe usage, consult your local Aeroboom sales office or distributor who can offer training courses for operators.

**⚠ WARNING!** Failure to observe and obey the following safety precautions could result in property damage, significant personal injury or death;

### 2.2 Work Area Safety

- Keep work areas clean and well lit. Cluttered spaces and inadequate lighting can result in unnecessary accidents.
- Keep bystanders clear of any hydraulic tool activity. Personnel working in close-range should be made aware of all high-pressure work before commencing.
- Ensure that lifting devices are placed entirely under the load and that lifting is parallel.

### 2.3 General Hydraulic System Safety Precautions

**⚠ WARNING!** Failure to observe and obey the following safety precautions could result in property damage, significant personal injury or death;



- When operating any hydraulic equipment, all operators should ensure that all necessary personal protective equipment (PPE) is worn, as specified by their employer. Steel toe-cap safety shoes, safety glasses/visor, and protective gloves should be worn at all times. All relevant risk assessments should be completed before the use of the equipment.
- Keep hydraulic equipment away from open flames and direct heat.



- Inspect hoses regularly for damage and wear.
- **NEVER** use hoses that are frayed, kinked, abraded or leaking.
- **NEVER** handle a pressurised hydraulic hose. Hydraulic fluid escaping under pressure from a ruptured hose can penetrate the skin and lead to a significant medical emergency, and in some cases, death. If this incident occurs, seek out medical attention immediately.
- Seek medical attention immediately if a hydraulic injection injury (no matter how minor) occurs.
- The system operating pressure **MUST NOT** exceed the pressure rating of the lowest-rated component in the system.
- Only use hydraulic cylinders in a complete and tested, coupled system. **NEVER** attempt to use a cylinder that is not correctly coupled to its operational pump.

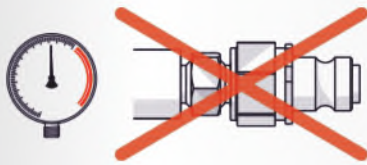

- **NEVER** pressurise an unconnected male coupler/s.

- **NEVER** attempt to disconnect a hose from a hydraulic system until the system's pressure has been completely released. Doing so can result in that pressure becoming trapped within the system and relieving trapped pressure can be dangerous.
- **NEVER** try to relieve trapped hydraulic pressure in the system by loosening or attempting to remove the coupler. Trapped hydraulic pressure can cause a loosened coupler to dislodge unexpectedly with great force. This action could result in serious personal injury or death.
- Loosening a coupler under pressure can result in the escape of hydraulic oil at high pressure, which can penetrate the skin and cause significant injury or death.
- **NEVER** use a hammer and punch to unseat a coupler check valve that is under pressure. Doing so could result in the sudden, uncontrolled release of hydraulic oil at high pressure, which could cause significant injury or death.
- **NEVER** attempt to solve, or clean-up leaks in the system while the system is pressurized.
- Immediately replace any worn or damaged parts using genuine Aeroboom parts only.
- **DO NOT** use any hydraulic equipment if you are under the influence of alcohol, drugs or medication. Lack of attention whilst operating high-pressure hydraulic tools can result in personal injury or death.

**CAUTION!**

**Failure to observe and obey the following safety precautions could result in property damage, equipment damage or minor/moderate personal injury;**

- **NEVER** lift, carry or move any hydraulic components by the hose or hoses connected to them.



- Avoid damaging hydraulic hoses. **ALWAYS** route hoses to ensure that they are free from sharp bends and kinks. Using a sharply bent or kinked hose will result in severe back-pressure, which can lead to hose failure.
- **NEVER** use a coupler/s to lift, carry or position a cylinder.
- Servicing of hydraulic equipment must only be undertaken by a qualified technician.



- **DO NOT** drop or place heavy objects on a hydraulic hose, as this may cause internal damage, which could result in rupture of the pressurised hose. A ruptured hose could cause significant damage to components and possible severe injury to personal operating nearby.

- **DO NOT** let familiarity gained with any hydraulic equipment allow you to become complacent. Complacency with any equipment can result in a lack of discipline toward working guidelines and safety principles.
- **DO NOT** remove any labels from the product. Replace any damaged or unreadable labels immediately.

## 2.4 Hydraulic Cylinder Specific Safety Precautions

 **WARNING!** Failure to observe and obey the following safety precautions could result in property damage, serious personal injury or death;

- **DO NOT** work under or near a load supported only by hydraulic means. A cylinder, when used as a lifting device, should not be used as a load-holding device. Once lifted, all loads should be supported using rigid mechanical structures.

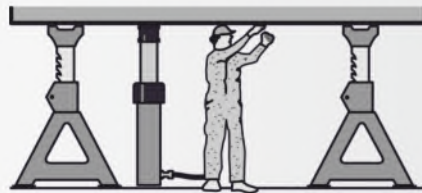

- **NEVER** exceed the maximum rated capacity of any hydraulic equipment. Aeroboom manufactures ARSM hydraulic cylinders to operate at a maximum working pressure of 700 bar (10,000 psi). Overloading hydraulic cylinders can result in component failure and possible serious personal injury.
- **DO NOT** connect a hydraulic pump with a higher pressure capacity rating to any Aeroboom cylinder of this model series.
- **ALWAYS** make sure that all equipment connected to the cylinder is in good working condition.
- **DO NOT** weld any items to the cylinder unit or modify it in any way from its delivered condition. Your warranty may be invalidated, and it could lead to serious personal injury.
- **NEVER** attempt to connect or disconnect a tool / hose / component while the system is under pressure.
- **NEVER** leave a pressurised system unattended. If you must leave the area, release the pressure and ensure the hydraulic relief valve on the pump is fully open.

### 3.0 Declaration of Incorporation/Conformity

Aeroboom declares that this product has been tested and complies with the standards and declarations as set out in the Declaration of Incorporation/Conformity (DoI/DoC). The DoI/DoC is included as Annex A to this instruction document and is supplied with all shipments of this product.

**4.0 Component Identification**

<b>1</b>	Cylinder Body	<b>4</b>	Female Coupler
<b>2</b>	Piston Stop Ring	<b>5</b>	Dust Cap
<b>3</b>	Piston/Saddle	<b>6</b>	Handle (ARSM1000 & ARSM1500 Only)

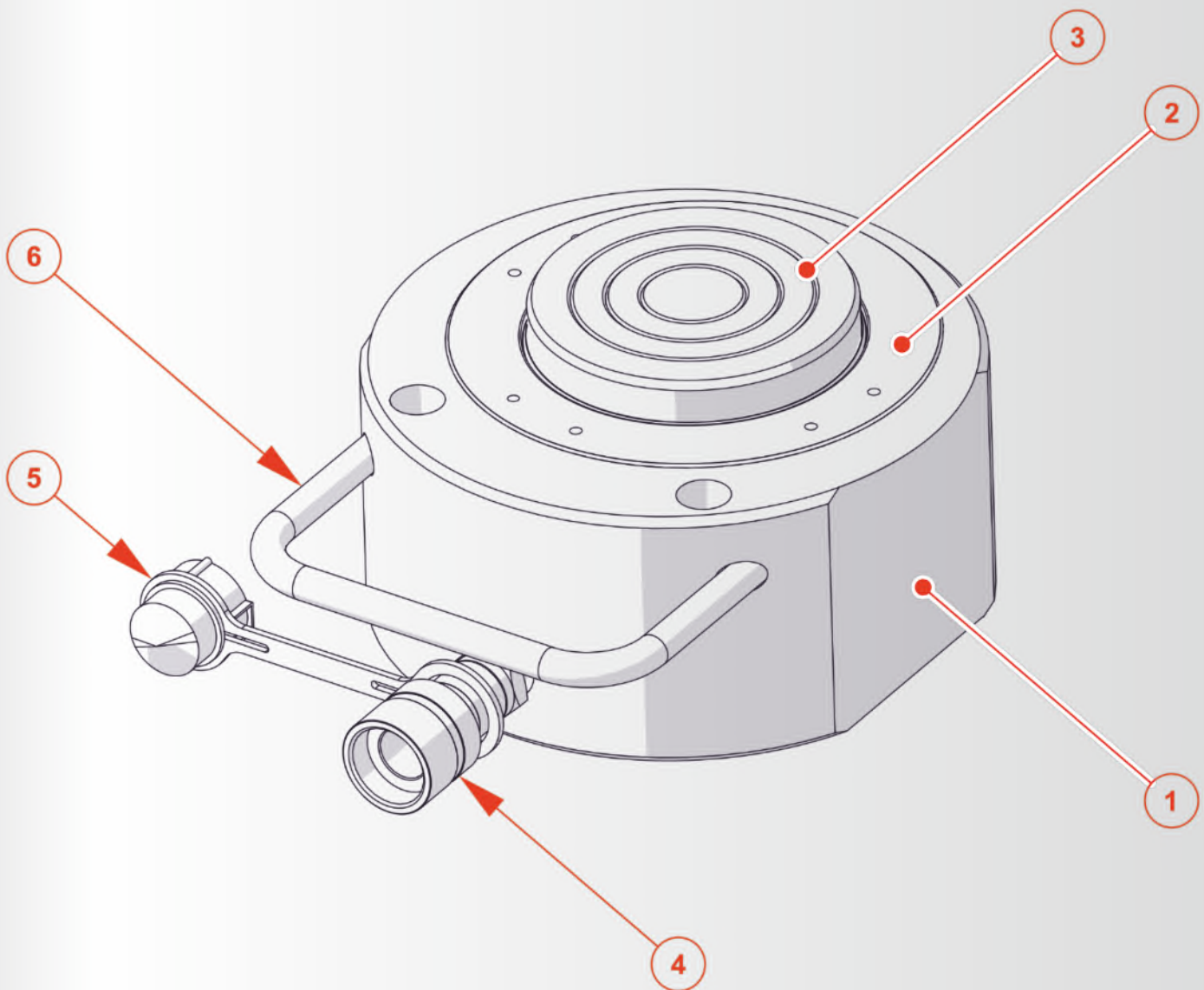



## 5.0 Installation/Setup

### 5.1 Pump Requirements

Ensure that the hydraulic pump to be used is suitable for the cylinder/s to which it will connect. For a single-acting cylinder (one pressure coupling connection), a single-acting hydraulic pump fitted with either a 2-way or 3-way valve and a single, correctly rated hose, must be used.

### 5.2 Hydraulic Connections

Connect the hydraulic hose/s between the cylinder/s and the pump, ensuring that the coupler/s are **fully hand-tightened ONLY**. To do so: [1] Press the male coupler into the female coupler (1), [2] then turn the threaded-collar clockwise (by hand) until the threads are fully engaged.

**⚠ CAUTION!** NEVER use wrenches in an attempt to connect the coupling/s. Incorrectly connected coupling/s are one of the most common causes of faulty operation.

**IMPORTANT:** Make sure that all coupler threads are fully engaged. (See figure 5.2, panel 3)

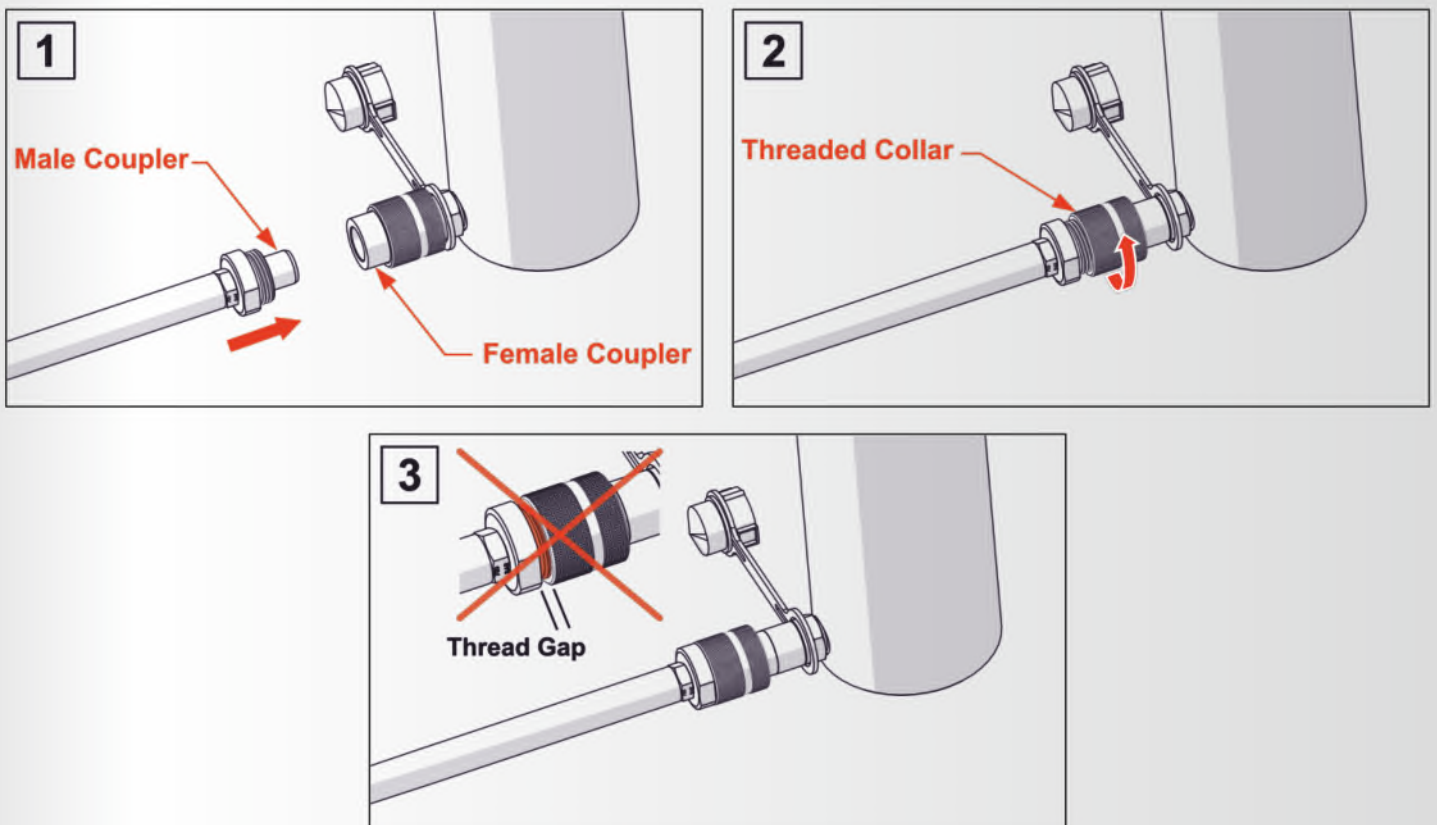

Figure 5.1: Hydraulic Connection



### 5.3 Bleeding Trapped Air from the System

**⚠ WARNING!** The bleeding of trapped air from a hydraulic system must only be performed by qualified personnel who have been trained and are competent to do so.

Cylinder and hoses are not always completely filled with oil when new. For safe and efficient operation, trapped air must be removed from the system. The follow procedure must be carried out with the cylinder/s connected to the pump, but not operating under load.

To remove air from the system, proceed as detailed below:

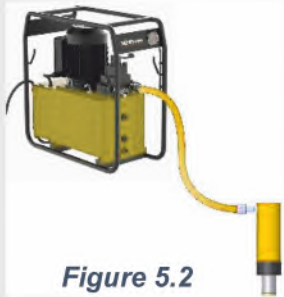

*Figure 5.2*

- Make sure the pumps oil filler breather cap is fitted. (if applicable)
- With all hydraulic connections made, position the cylinder/s below the level of the hydraulic pump, as illustrated in figure 5.2.

**Double-Acting:** If possible, position double-acting cylinders on their side with the couplers facing upward, as illustrated in figure 5.3.



*Figure 5.3*

Using the pump, fully advance and retract the cylinder/tool piston several times until the operation is smooth. (Refer to the pumps operating manual for details of pump operation).

### 5.4 Mounting the Cylinder.

Refer to the Aeroboom Website or the latest Aeroboom Catalogue for Thread size and bolt spacing dimensions.

## 6.0 Operation

A hydraulic pump is required to operate the cylinder range covered in these instructions. Please refer to the relevant 'Aeroboom hydraulic pump operating instructions' for full details of the chosen pumps applicable operating instructions.

Single-acting cylinders have 2-different methods of return of the piston. They are either spring-assisted return or load-assisted return. ARSM cylinders are spring assisted return.

### Operating Orientation

- Aeroboom cylinders can operate in any orientation.

**⚠ CAUTION!** When lowering loads, the load may descend faster than expected. For precise lowering control, Aeroboom recommends the use of a manual check valve.

**ALWAYS** ensure the cylinders piston contacts the load to be lifted as squarely as possible.

## 7.0 Maintenance and Storage

Carry out basic maintenance on a regular basis to keep the cylinder operating in a trouble-free manner. Maintenance intervals are determined by the frequency of use and the operating conditions on site.

- **ALWAYS** use Aeroboom specified hydraulic oil grades with the cylinders. The use of other fluids may invalidate your warranty.
- After use, always retract the cylinder/s fully before disconnecting the hose/s.
- Fit dust caps (5) to the couplers, every time disconnections are made.
- Regularly inspect (before and after every use) the cylinder and all accessories for damage.
- Inspect the cylinder periodically for paint damage. Clean and touch up any exposed surfaces to prevent corrosion.
- Inspect hoses regularly for damage and wear. **DO NOT** use hoses that are frayed, abraded or leaking.
- Make sure the cylinder is clean before placing it into storage. Remove any dirt or debris which may have been picked up while on site.
- Store the cylinder/s in a clean and dry environment.
- If storage is to be for a prolonged period, it is advisable to apply grease to exposed metal surfaces.
- **NEVER** store, transport or lift a cylinder with its piston in the extended position.



## 8.0 Specifications

### 8.1 Oil Specifications

Aeroboom tools will use 1 of 2 grades of oil, dependant on the pump used. The tools are designed to operate at temperatures between -20°C and 80°C. Details of the oil used can be found in the chosen Aeroboom pump's operating manual, in the section:

### 8.2 ARSM Specifications

Refer to the engraved detail on the cylinder for model identification.

Model Number	Cyl. Capacity	Stroke	Cylinder Effective Area	Oil Capacity	Collapsed Height	Extended Height	Outside Diameter	Cylinder Bore Dia.	Plunger Dia.	Base to Advance Port	Plunger Protrusion from Base	Plunger to Base	Plunger to Mtg. Hole	
	ton	(mm)	(cm <sup>2</sup> )	(cm <sup>3</sup> )	A (mm)	B (mm)	D (mm)	E (mm)	F (mm)	H (mm)	K (mm)	L (mm)	M (mm)	(kg)
ARSM-50 <sup>1)</sup>	5	6	6,5	4	32	38	58 x 41	28,7	25,4	16	1	20	22	1,0
ARSM-100	10	11	14,5	18	43	54	82 x 55	42,9	38,1	19	1	27	34	1,4
ARSM-200	20	11	28,7	32	51	62	101 x 76	60,5	50,8	19	1	39	39	3,1
ARSM-300	30	13	42,1	55	58	71	117 x 95	73,2	63,4	19	2	47	44	4,5
ARSM-500	50	16	62,1	99	66	82	140 x 114	88,9	69,8	19	2	57	53	6,8
ARSM-750	75	16	102,6	164	79	95	165 x 139	114,3	82,6	19	2	69	66	11,3
ARSM-1000	100	16	126,7	203	85	101	178 x 153	127,0	92,2	19	2	76	74	14,5
ARSM-1500	150	16	198,1	317	100	116	215 x 190	158,8	114,3	23	2	95	82	26,3

### **9.0 System Components / Accessories**

*(Refer to the Aeroboom website or latest Aeroboom catalogue for further details)*

- High-Pressure Hydraulic Hoses
- Manifolds and Manifold Assemblies.
- Flow Control Valve
- Pressure Gauges and Gauge Mounting Blocks
- High-Pressure Couplers and Fittings



### 10.0 Troubleshooting

The Aeroboom APE electric-driven hydraulic pump should be serviced and repaired only by authorised Aeroboom repair centres. The following table gives possible causes and solutions for common problems.

<b>TROUBLESHOOTING GUIDE</b>		
<b>Problem</b>	<b>Possible Cause</b>	<b>Solution</b>
1. Piston will not advance.	a. Pump release valve open.	Close pump release valve.
	b. Coupler not fully tightened.	Tighten coupler.
	c. Oil level in pump is low.	Add oil to pump reservoir.
	d. Pump malfunctioning.	Repair or replace pump.
	e. Load is too heavy for cylinder.	Use correctly rated cylinder for load.
	f. Cylinder seals leaking.	Repair or replace cylinder.
2. Cylinder advances part way.	a. Oil level in pump is low.	Add oil to pump reservoir.
	b. Coupler not fully tightened.	Tighten coupler.
	c. Cylinder piston binding.	Repair or replace cylinder.
3. Cylinder advances in spurts.	a. Air in hydraulic system.	Bleed air from system. ( <a href="#">See section 5.3</a> )
	b. Cylinder piston binding.	Repair or replace cylinder.
4. Cylinder advances slower than normal.	a. Leaking connection.	Replace faulty component.
	b. Coupler not fully tightened.	Tighten coupler.
	c. Pump malfunctioning.	Repair or replace pump.
5. Cylinder advances, but will not hold.	a. Pump malfunctioning.	Repair or replace pump.
	b. Leaking connection.	Replace faulty component.
	c. Incorrect system setup.	Check system setup.
	d. Cylinder seals leaking.	Repair or replace cylinder.
6. Cylinder leaks oil.	a. Worn or damaged seals.	Repair or replace cylinder.
	b. Internal cylinder damage.	Repair or replace cylinder.
	c. Loose connection.	Tighten or repair connection.
7. Cylinder will not retract or retracts slower than normal.	a. Pump release valve is closed.	Open pump release valve.
	b. Coupler not fully tightened.	Tighten coupler.
	c. Pump reservoir over-filled.	Drain excess oil from pump reservoir.
	d. Narrow hose restricting flow.	Replace with larger diameter hose.
	e. Cylinder damaged internally.	Repair or replace cylinder.





# WORLDWIDE HYDRAULIC SOLUTIONS

## AEROBOOM CORPORATION

### INDIA

Laxmi Industrial Estate, Suite No: 617, 6th Floor, Laxmi Plaza,  
New Link Road, Andheri (W) Mumbai - 400053, Maharashtra, India.  
Ph: +91-22-4010 4288

### GERMANY

Hans Geiger-Str, 221465 Reinbek Germany.

### UNITED KINGDOM

124 City Road, London, EC1V 2NX, United Kingdom.

### YOUR NEAREST DISTRIBUTOR

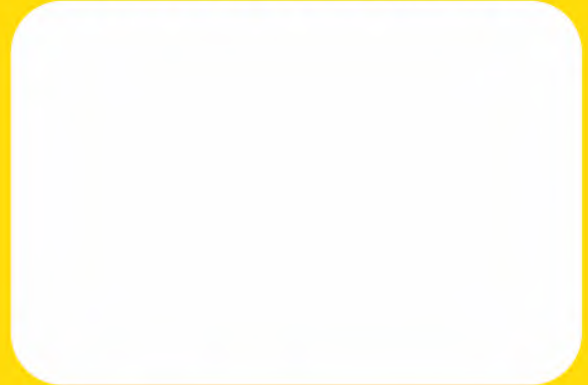

Email: [info@aeroboom.com](mailto:info@aeroboom.com)

Web: [www.aeroboom.com](http://www.aeroboom.com)

## LIFETIME WARRANTY

*Aeroboom warrants all of its products to be free from defects in material and workmanship for the life of the product. This warranty applies to original purchaser and is not transferable. Damaged components, including broken welds, dented or crushed cylinder walls, bent pistons, or couplers are the result of misuse, and are not covered under this warranty. Items such as seals, o-ring and spring wearing out shall not constitute a defect and shall not be considered for warranty credit. We believe that the Aeroboom products you purchase will meet or exceed your performance requirements. However, in the unlikely event that an Aeroboom product fails due to material or workmanship defect please contact Aeroboom, to have it resolved.*



Aeroboom does reserve the right to make changes to the specifications of any product or discontinue any product, contained within this catalogue without prior notice.

